



# ASTRA 777 Mobile



## VEHICLE SECURITY SYSTEM PRODUCT MANUAL

## Limited Lifetime Warranty

This vehicle security system is warranted to the original purchaser, to be free from defects in material and workmanship. The manufacturer will repair or replace at its option, and free of charge for the first twelve (12) months, any part that proves defective in material or workmanship under normal installation, use, and service, provided the product is returned to the manufacturer freight prepaid. After the first 12 month warranty period there will be a maximum service charge of \$25.00 per calendar year (if required) for repair and/or replacement of any defective parts.

**A copy of the original purchase and installation receipt must accompany any products returned for warranty service.** Warranty is limited to defective parts and/or replacement parts only and excludes any incidental, and consequential damages connected therewith. The manufacturer of this theft deterrent system makes no warranty against the theft of the vehicle or its contents. This warranty is not to be construed as an insurance policy against loss.

WARRANTY OF INSTALLATION LABOR, REMOVAL AND RE-INSTALLATION CHARGES ARE NOT THE RESPONSIBILITY OF THE MANUFACTURER.

**Note: This Warranty is voided if the product was not installed by an Authorized ScyTek Dealer.**

# Table of Contents

# About Your System

Congratulations on your purchase of this state-of-the-art vehicle security system from ScyTek Electronics. With proper installation this system will provide superior protection and performance for many years to come.

The Astra 777 Mobile is a Vehicle Tracking System

System Features:

- Unlimited Real-time GPS tracking with user-friendly internet software
- Fast Response Time
- High gain GPS/Cellular antenna
- Issue commands via internet or web enabled Smart Phone
- Door Lock/Unlock, remote start, starter disable/enable, flash horn
- Notification alerts sent to cell phone and email address
- Excessive speed , theft daily curfew, geo-fencing, Alarm triggers
- Engine on /off reports
- Multi vehicle monitoring

## System Contents:

Main Unit

One 5-Button Random Code Remote Transmitter

2-Way Pager Transceiver Antenna

High Output 6-tone Siren

Dual Stage Shock Sensor

Status LED

Coded Emergency Override/ Valet Switch/Call Button built into the antenna

**\*May require additional parts and/or labor, see store for details.**

## Options and Accessories\*

- Second Car Operation
- Remote Door Locking
- Two Stage Door Unlocking
- Starter Defeat
- Horn Honk
- Illuminated Entry
- Remote Window Control
- Extended Range Antenna
- Power Trunk / Hatch Release
- Glass Breakage Sensor
- Radar Sensor
- Auxiliary Lighting Control
- Back-up Battery Siren

**Some of the features described in this manual may require additional parts and/or labor, and may not be included as part of the standard installation of this unit. Additionally, many features of this security system have selectable options that must be activated or programmed during the system's installation. These items will be identified in the following sections. Please discuss these features and any questions you may have regarding the installation of this product with Your Authorized Dealer.**

# Quick Start Guide for Astra Mobile

## System Registration:

To Register your Astra 777 Mobile:

Login on to [www.scytrak.net](http://www.scytrak.net)

Click on the "Click to register"



# New Master Account Registration Page

New Master Account Registration screen.

In the "User ID" area type in your login ID, then complete the rest of the information.

After completing Master Account registration page, click on "O.K." at the bottom far right side.

**Real-Time Vehicle Tracking System**

[Home](#) / [Terms of Use and Privacy Policy](#) / [Support](#) / [Help](#)

### • New User Account Registration

▶ Username : scytek

▶ Password : [redacted]

▶ Retype Password : [redacted]

▶ Name : Mark Notel

▶ Email : mark@gmail.com

▶ Phone Number : 8182526678

▶ Address : 11627 cantara st

▶ City : North Hollywood

▶ State : CALIFORNIA (CA) ▼

▶ Zip : 91605

▶ Terms of Use and Policy

End-User Service Terms and Conditions

Copyright (C) 2007

Scytek Inc. 11627 Cantara St. North Hollywood, CA 91605 Tel: (800) 693-7505  
Fax: (818) 767-3073  
scytek@scytek.net

1. Acceptance of Terms:  
This service is provided to you subject to the following Terms and Conditions ("T&C"). Scytek Inc., hereafter known as (Scytek Inc.) may change or update the T&C from time to time without notice to you. Scytek Inc. is only willing to provide the service to you upon these T&C and your activation of the service

I Agree

OK Cancel

# New Vehicle Registration Page

## New Vehicle Registration screen

In the "Vehicle's ID " area type in the Vehicle name such as Johny's Car or Vehicl's model, then complete the rest of the information.

**Vehicle / Management**

Vehicle Name: Demo-1  
Vehicle Model: Demo  
Group Name: ScyTek  
Device S/N: c0501  
Eastern Hemisphere:   
Timezone: (GMT-08:00) Pacific Time (US & Canada)  Daylight Savings Time

Alert Recipients:

Edit SMS Recipients  
3103145679/AT&T  
8182526678/AT&T

Edit Email Recipients  
notel@gmail.com  
john@msn.com  
Jane@gmail.com

Vehicle Icon:

Save Reset



## Billing Information Page

Billing information screen.

In the Service Term Area, select the yearly plan that you like. then complete the rest of the information.

• Billing Information	
▶ Service Terms	: One Year (\$180) ▾
<hr/>	
▶ Card Type	: Mastercard ▾
▶ Card Number	: 3333444455556666
▶ Name on Card	: Mark Notel
▶ Expiration Date	: Month: 05-May ▾ / 2013 ▾
<hr/>	
▶ Address	: 11627 Cantara St
▶ City	: North Hollywood
▶ State	: CA
▶ Zip Code	: 91605
▶ Phone Number	: 8182526678
<hr/>	
<input type="button" value="Submit"/> <input type="button" value="Cancel"/>	



## Sub User Page

Subuser account allows for additional users to manage the fleet vehicles with varies degrees of control.

The screenshot displays the 'Subuser Management' interface. On the left, a sidebar lists various configuration categories: Full Name, User Name, Password, Email, Phone, Measurement, Permissions, and Vehicles. The main area shows the details for a user named 'Jim Notal'. The 'Permissions' section includes checkboxes for View/Track, Basic Command, Security Command, Vehicle Management, and Alert Setup. The 'Vehicles' section contains a table with two entries:

Serial No	Device	Model	Group	
c0501	Demo-1	Demo	Soytek	<input checked="" type="checkbox"/>
c0504	Demo 2	Demo 2	SoyTek	<input type="checkbox"/>

At the bottom, there are 'Save' and 'Clear Form' buttons, a message stating 'There was no data returned for the report', and a pagination control showing 'Record count: 0' and 'Page 1 of 1'. A search bar is also present with the text 'Find: Name' and a 'Search' button.

Click on Subuser Management to edit the page.

This is a duplicate of the screenshot above, showing the 'Subuser Management' page with the same user details and vehicle assignments.

Register the sub user and assign the vehicles and checkmark the desired privilege of the user. More than one sub user can be assigned to that vehicle group.

## Astra Mobile Page

login page [www.scytrak.net](http://www.scytrak.net)

Astra 777 Mobile GPS Login Page:

Login: input your Login ID and your Password. "you may change your password at any time for your personal security" Click on the field marked "Sign in" and you will then be taken to your Astra 777 Mobile GPS Home Page.



# Home Page

Your Astra 777 Mobile GPS Home Page will have your vehicle(s) listed and look very similar to this. Click on the Vehicle name to select that particular vehicle, the screen will refresh displaying the map with the breadcrumb trail showing the last locations of the vehicle.



Month/Day/Year/Hour  
Mar 3 2010 AM

Track Latest / Update

List Duplicate Events  
Auto-Refresh

Group: All

Vehicle List

- 1 Demo-1
- 2 Demo-2

Track Output

Track Output

Home / Terms of Use and Privacy Policy / Support / Help

Tracking | Reports | Account | Vehicles | Landmarks

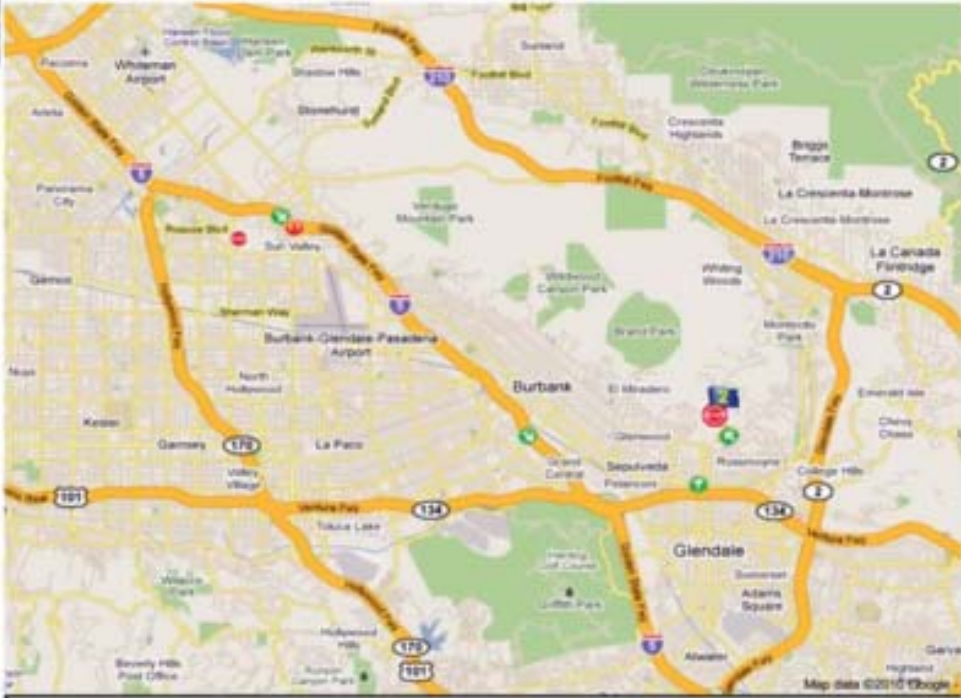

Device model: 3000

One event \* 10 events 40 events 80 events

Expiration: 12/31/2010

San-Peace ECG2, Tom-Peace ECG2, Speed-Fence ECG2, 1885-Ann ECG2

ECG2 Input 1, ECG2 Input 2, ECG2 Input 3, ECG2 Input 4

Vehicle 2: Demo-2 Showing 1 - 10 of 57

Date	Time	Status	Alert	Landmark	Address	MPH	Direction
3/3/2010	3:04 PM	Engine off (avg)	Normal	set	2083-2097 Fincrest Dr, Glendale, CA	0	N
3/3/2010	3:42 PM	Ignition off	Normal	set	2083-2097 Fincrest Dr, Glendale, CA	0	N
3/3/2010	3:38 PM	Idle	Normal	set	1600-1698 Ridgeview Dr, Glendale, CA	0	N
3/3/2010	3:33 PM	Driving	Normal	set	1644 Ceiba Dr, Glendale, CA	28	SW
3/3/2010	3:28 PM	Driving	Normal	set	901 N Central Ave, Glendale, CA	0	N
3/3/2010	3:23 PM	Driving	Normal	set	Golden State Fwy, Burbank, CA	83	SE
3/3/2010	3:18 PM	Driving	Speed alert	set	Golden State Fwy, Sun Valley, CA	76	S
3/3/2010	3:18 PM	Driving	Normal	set	Golden State Fwy, Sun Valley, CA	71	SE
3/3/2010	3:13 PM	Ignition on	Normal	set	11627 Carosa St, Sun Valley, CA	0	N
3/3/2010	1:03 PM	Ignition off	Normal	set	11627 Carosa St, Sun Valley, CA	0	N

GPS Tracking Service Powered by Sylek Inc.  
11627 Carosa St, North Hollywood, CA 91605 Tel: (805) 883-7505 Fax: (818) 767-3073 Email: [sylek@sylek.net](mailto:sylek@sylek.net)



# Vehicle Alert Page

## Vehicle Alert Window:

Vehicle alert window is located below the map, it contains;

Number of events displayed on the map Select the number of events on the map by selecting 1, 10, 40 or 80, recorded events will be displayed showing the state of the vehicle and the direction of the motion.

Contract expiration date Current state of the subscription.

Current alert state alerts that are enabled are highlighted. Edit the alert selection by clicking on any of Alert buttons.

**Vehicle Alert Window**

Time	Status	Alert	Landmark	Address	MPH	Direction
3/3/2010 3:24 PM	Engine off (long)	Normal	set	2000-2087 Riverside Dr, Glendale, CA	0	↻ N
3/3/2010 3:42 PM	Ignition off	Normal	set	2000-2087 Riverside Dr, Glendale, CA	0	↻ N
3/3/2010 3:36 PM	Idle	Normal	set	1600-1696 Ridgeway Dr, Glendale, CA	0	↻ N
3/3/2010 3:33 PM	Driving	Normal	set	1644 Cielito Dr, Glendale, CA	28	↻ N
3/3/2010 3:28 PM	Driving	Normal	set	801 N Central Ave, Glendale, CA	0	↻ N
3/3/2010 3:23 PM	Driving	Normal	set	Golden State Fwy, Burbank, CA	83	↻ S
3/3/2010 3:18 PM	Driving	Speed alert	set	Golden State Fwy, Sun Valley, CA	78	↻ S
3/3/2010 3:18 PM	Driving	Normal	set	Golden State Fwy, Sun Valley, CA	71	↻ S
3/3/2010 3:13 PM	Ignition on	Normal	set	11827 Centere St, Sun Valley, CA	0	↻ N
3/3/2010 1:33 PM	Ignition off	Normal	set	11827 Centere St, Sun Valley, CA	0	↻ N

GPS Tracking Service Powered by Skytrak Inc.  
11827 Centere St, North Hollywood, CA 91605 Tel: (800) 655-7655 Fax (818) 707-3073 Email: support@skytrak.net

## System Alerts

### 1. Geo Fence Alert setup:

Type in the address of the Geo Fence window and the boundary size, chose if alert is for antry into or exit from the boundaries. Select the Geo Fence Alert.

### 2. Time Fence Alert:

Set the time alert window, when alert is on, if the vehicle ignition is turned on within the time window an alert will be set.

### 3. Speed Alert:

Select the speed threshold, when the alert is set, if the vehicle speed exceeds the set speed Alert is set.

### 4. SMS Alert:

SMS alert sends all alerts as a text message to the preset SMS and Email addresses specified in the vehicle setup window, note: that multiple Emails and text messages are allowed.

### 5. Input Alerts:

There are four alert inputs that can be selected. Inputs 1 2, and 3 are negative (ground). Input 4 is Positive (12V), this input when the Skytrak system is connected to ScyTek Astra 777 Mobile Security System is automatically reports an Alarm Alert. In stand-alone mode an alert will be set only if the input is valid for over 5 seconds. connect this input to the siren of vehicle alarm.

After completion of alert setup, Press the save button on the bottom of the screen to save the setup in the remote unit.

The **Success** response indicates the unit received the alert setup.

## Renaming Input Alerts

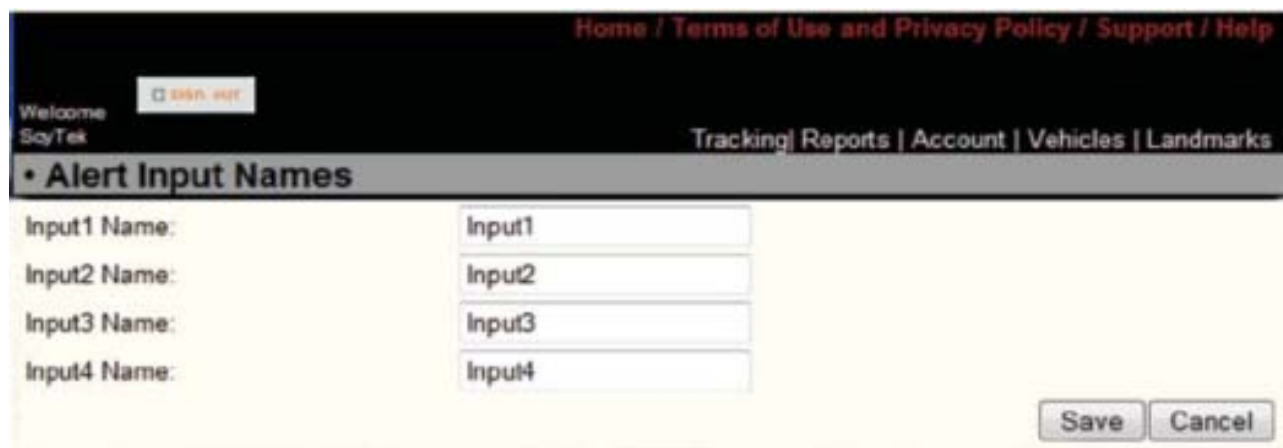

The screenshot shows a mobile application interface for ScyTek. At the top, there is a navigation bar with links for Home, Terms of Use and Privacy Policy, Support, and Help. Below this, a header bar displays 'Welcome ScyTek' on the left and 'Tracking | Reports | Account | Vehicles | Landmarks' on the right. The main content area is titled 'Alert Input Names' and contains four rows of input fields. Each row is labeled 'Input1 Name:', 'Input2 Name:', 'Input3 Name:', and 'Input4 Name:' on the left, and has a corresponding text input field on the right containing 'Input1', 'Input2', 'Input3', and 'Input4' respectively. At the bottom right of the form, there are two buttons labeled 'Save' and 'Cancel'.

# Astra Mobile Home Page

In the main Page provides tracking and control of the vehicles. View all vehicle locations on the map by checking the Check all box and clicking on the Track Today/Refresh button. Refresh location manually by clicking on the Track button of the specific vehicle. When success result appears the map will refresh automatically and display the latest vehicle location. Select the **auto refresh** mode to refresh the display once a minute automatically, this feature provides a live display of all the selected vehicles.

The screenshot displays the Astra Mobile Home Page interface. At the top, there are navigation links: Home / Terms of Use and Privacy Policy / Support / Help. Below this, a sidebar on the left contains the following elements:

- SKYTRAK 3000** logo and satellite imagery.
- Date and time: **Months/Day/Year/Hour** (Mar 3 2010 14).
- Buttons: **Track**, **Track Latest / Update**, **List Duplicate Events**, and **Auto-Refresh**.
- Group:** All
- Vehicle List:**
  - 1 Demo-1 **Track** **Output**
  - 2 Demo-2 **Track** **Output**

The main area features a map of the Burbank, CA region with several vehicle locations marked by colored icons. A detailed view for **Vehicle 2: Demo-2** is shown below the map, including a table of events.

**Device model:** 3000  
**Expiration:** 12/31/2010  
**Alerts:** One event, 10 events, 40 events, 80 events  
**Inputs:** Input 1, Input 2, Input 3, Input 4

Date	Time	Status	Alert	Landmark	Address	MPH	Direction
3/3/2010	3:04 PM	Engine off (sing)	Normal	set	2093-2097 Rimcrest Dr, Glendale, CA	0	N
3/3/2010	3:42 PM	Ignition off	Normal	set	2093-2097 Rimcrest Dr, Glendale, CA	0	N
3/3/2010	3:38 PM	Idle	Normal	set	1600-1606 Ridgeview Dr, Glendale, CA	0	N
3/3/2010	3:33 PM	Driving	Normal	set	1644 Cello Dr, Glendale, CA	28	NNW
3/3/2010	3:28 PM	Driving	Normal	set	301 N Central Ave, Glendale, CA	0	N
3/3/2010	3:23 PM	Driving	Normal	set	Golden State Fwy, Burbank, CA	83	SE
3/3/2010	3:18 PM	Driving	Speed alert	set	Golden State Fwy, Sun Valley, CA	76	S
3/3/2010	3:18 PM	Driving	Normal	set	Golden State Fwy, Sun Valley, CA	71	SE
3/3/2010	3:13 PM	Ignition on	Normal	set	11627 Carsons St, Sun Valley, CA	0	N
3/3/2010	1:03 PM	Ignition off	Normal	set	11627 Carsons St, Sun Valley, CA	0	N

GPS Tracking Service Powered by Spytek Inc.  
 11627 Carsons St North Hollywood, CA 91605 Tel: (818) 945-7555 Fax: (818) 957-3075 Email: spytek@spytek.net

## Outputs

SkyTrak system has been provided with four outputs.

The system is designed for stand alone use or with combination of ScyTek Security systems.

Using with combination of ScyTek Security

Output 3 - Arms or Disarms the Security System

Output 4 - Not Used

Output 1 - Trunk Release

Output 2 - Momentary activation of auxiliary output

Stand Alone Mode:

Output 1 and 2 are momentary, and output 3 and 4 are latched.

Activate each of the outputs by pressing the output button.

Output window will open to reveal the system outputs.



Click on send button to activate outputs 1 or 2, or **on** or **off** for outputs 3 and 4. state of the outputs 3 and 4 is also displayed.





## Landmark Management Page

From the vehicle history table click on the set button in Landmark column, the landmark window will open up.

Vehicle 2: Demo-2 Showing 1 - 10 of 57

Date	Time	Status	Alert	Landmark	Address	MPH	Direction
3/3/2010	9:04 PM	Engine off (ping)	★ Normal	set	2093-2097 Rimcrest Dr, Glendale, CA	0	📍 N
3/3/2010	3:42 PM	Ignition off	★ Normal	set	2093-2097 Rimcrest Dr, Glendale, CA	0	📍 N
3/3/2010	3:38 PM	Idle	★ Normal	set	1600-1698 Ridgeview Dr, Glendale, CA	0	📍 N
3/3/2010	3:33 PM	Driving	★ Normal	set	1644 Cielto Dr, Glendale, CA	28	📍 NW
3/3/2010	3:28 PM	Driving	★ Normal	set	901 N Central Ave, Glendale, CA	0	📍 N
3/3/2010	3:23 PM	Driving	★ Normal	set	Golden State Fwy, Burbank, CA	83	📍 SE
3/3/2010	3:18 PM	Driving	🚨 Speed alert	set	Golden State Fwy, Sun Valley, CA	76	📍 S
3/3/2010	3:18 PM	Driving	★ Normal	set	Golden State Fwy, Sun Valley, CA	71	📍 SE
3/3/2010	3:13 PM	Ignition on	★ Normal	set	11627 Cantara St, Sun Valley, CA	0	📍 N
3/3/2010	1:03 PM	Ignition off	★ Normal	set	11627 Cantara St, Sun Valley, CA	0	📍 N

Select the appropriate icon and name the landmark. The icon will appear on the map for easy vehicle location identification.









Landmark Name:

Address:

Latitude:

Longitude:

Landmark Icon:

ID	Landmark Name	Address	Latitude	Longitude	Delete
1	Office	11627 Cantara St, Sun Valley, CA 91352, USA	34.219560	-118.385508	✕

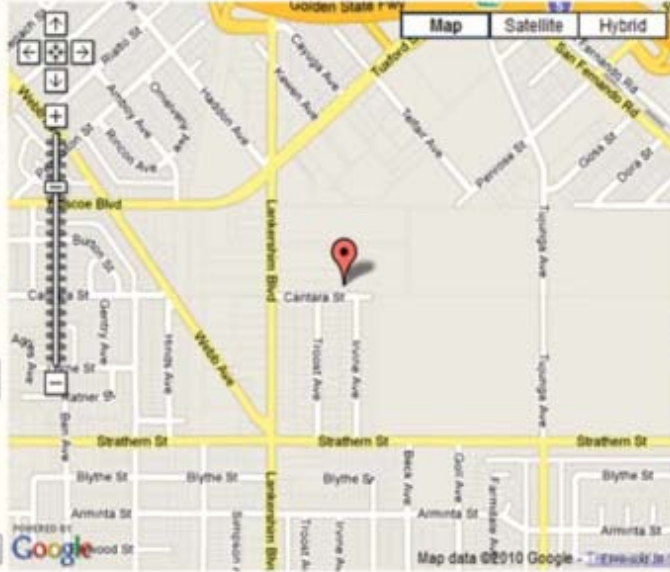
Record count: 1

Page 1 of 1

show 10 per page

Find:  Landmark Name

# Smart Phone

## Smart Phone features:

Arm/Disarm

Trunk Release

2 way confirmation

GPS Tracking

Alert notification via SMS and Email

Control multiple cars

Login using your smart phone to: [www.skytrakmobile.com](http://www.skytrakmobile.com)

Login Page



SCYTEK  
ELECTRONICS

Welcome to Skytrak Mobile!

Account Information

Username  
**Notel**

Password  
●●●●●

Log On • Remember me?

Login using user ID and password.

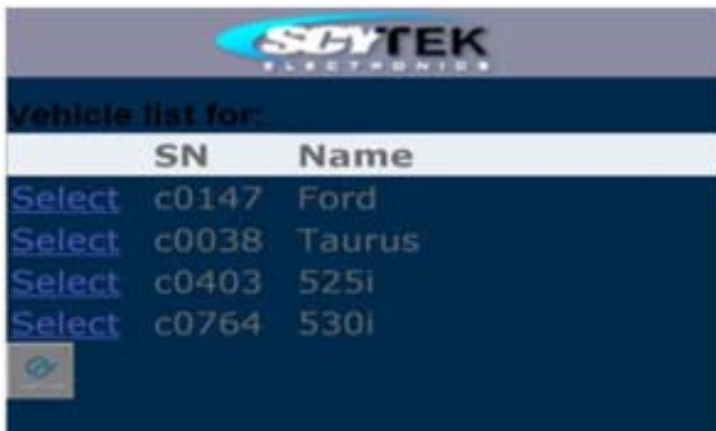

SCYTEK  
ELECTRONICS

Vehicle list for:

	SN	Name
Select	c0147	Ford
Select	c0038	Taurus
Select	c0403	525i
Select	c0764	530i

Select the vehicle, and go to vehicle control page Vehicle Control Page

# Smart Phone

## Vehicle Control Page



- 1 Arm and Lock
- 2 Disarm and Unlock
- 3 Trunk Release
- 4 Remote Engine Start (Not Used)
- 5 Remote Engine Stop (Not Used)
- 6 Locate Vehicle on the map
- 7 Request vehicle GPS location and system status
- 8 Refresh screen
- 9 List event history
- 10 Select Vehicle
- 11 Log Off
- 12 Security system status
- 13 Remote start status

# Smart Phone

Vehicle event history page



Vehicle GPS Location



The main unit can be mounted under the dashboard.  
The GSM/GPRS antenna affixes to the windshield with the double sided tape.  
The GSM can be hidden under the dashboard.

## Optional 2-way LCD Remote Transmitter Description

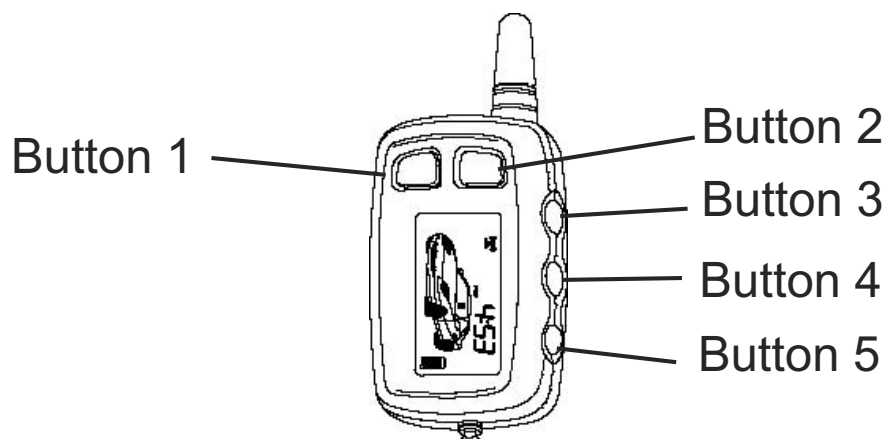

The Astra's 777 Mobile 2-way LCD remote transmitter is offering increased range and confirmation of any activated feature.

### Page 1

Button 1 Arms and Locks\* the system and when held for 5 seconds, activates the system's Panic feature.

Button 1 also locks the doors when the system is in Valet Mode. Button 2 Disarms and Unlocks\* the system. Pressing Button 2 again operates the Passenger Unlock feature (if installed). Button 2 also unlocks the doors when the system is in Valet Mode.

Button 3 Activates the Auxiliary 1 output normally used for trunk release (note trunk icon on button).

Button 4 Activates the Auxiliary 2 output. Button 5 is the Confirmation, Programming and the Page Shift button. Quickly pressing button 5 will activate the **Page 2 function**. Pressing button 5 for 2 seconds activates the system's confirmation feature which will then display the current status of the system (armed, disarmed, engine running, etc.).

### Page 2

Button 5 then Button 1 : Silently Arms and Locks\* the system. Button 1 also locks the doors when the system is in Valet Mode. Button 5 then Button 2: Silently Disarms and Unlocks\* the system, also unlocks the doors when the system is in Valet Mode.

\* **If the Optional Keyless Entry Feature is installed.**

## **Adding/Replacing 2-way Optional LCD Transmitters (2 LCD remotes maximum)**

When adding an optional 2-way LCD transmitter to the system, follow these steps:

Turn on the ignition key On, Off, On, Off, On, Off, and back On. (Key On 4 times)

The siren will chirp 4 times.

Press and hold the Override switch for 5 seconds.

The siren will chirp 4 times.

The LED will illuminate.

Press Button 1 on the first transmitter, then on the second transmitter.

The siren will chirp once for each transmitter learned.

Turn off the ignition key.

The siren will chirp 3 times to indicate the system has exited programming mode.

1. Press and hold Buttons 2 and 3 for three seconds.

- The remote will beep two times and three bars will be shown indicating time set mode is entered.

## **LCD Transmitter Battery Replacement**

Your Astra Remote Transmitter uses a 1.5 volt AAA alkaline battery, which will require replacement in time. Depending on the amount of use, the battery may last up to three months before it needs replacement. When the battery needs replacing, the system's operating range will decrease, the LCD display will show only one of three bars in the battery icon, or the display and sounds may suddenly stop and start as the battery voltage drops below minimum.

In order to change the battery, first slide the battery door locking pin to the side. Carefully slide the battery cover downward until it is free. While replacing the battery make sure that the positive and negative terminals are positioned correctly, then carefully reassemble the transmitter case.

## **Setting The Time**

The LCD display is equipped with a 12-hour clock that in addition to displaying the time, offers an alarm clock function as well as a remote activation timer.

To set the time:

1. Press and hold Buttons 2 and 3 for three seconds.

- The remote will beep two times and three bars will be shown indicating time set mode is entered.

2. Press Button 2 until the correct hour is displayed.

3. Press Button 3 until the desired minute is displayed. The button may be held down to scroll faster.

4. When the desired time is displayed, press Button 5 to store. · The remote will beep 3 times to indicate the time has been set.

## **Setting The Alarm Clock**

The alarm clock function can be set to play an alert melody at a specific time of day.

To set the alarm clock function:

1. Press and hold Buttons 2 and 3 until the remote beeps three times.

- The alarm clock bell and three bars will be shown indicating alarm clock set mode is entered.

2. Press Button 2 until the desired hour is displayed.

3. Press Button 3 until the desired minute is displayed. The button may be held down to scroll faster.

4. When the desired time is displayed, press Button 5 to store.



- The remote will beep 3 times to indicate the alarm clock has been set. To disable the alarm clock function:  
Press and hold Buttons 2 and 3 until the remote beeps three times. · The alarm clock bell and three bars will be shown indicating alarm clock set mode is entered.  
Press Button 1 to disable the alarm clock. · The remote will beep 3 times to indicate the alarm clock has been disabled.

### **LCD Backlight**

Transmitter Button 5 is used for confirmation, transmitter programming, as well as activation of the LCD backlighting for use in the dark. Press button 5 to activate the LCD backlight.

### **System Confirmation**

The 2-way transmitter's confirmation feature allows the current vehicle status to be displayed at any time.

To display system status:

- Press and hold Button 5 until the display shows CON.
- The transmitter will beep once.  
Release Button 5.
- The transmitter will beep once.
- The icon representing the system's current status will be displayed on the LCD panel.

### **Transmitter Programming**

Pressing and holding transmitter button 5 will scroll through several transmitter programmable options that may or may not be available depending on the model of system installed **DEG** (degress)

**Not applicable on this model.**

**CHP** Sets the siren confirmation chirps ON or OFF:

- Press and hold Button 5 until the display shows CHP.
- The transmitter will beep 3 times.  
Release Button 5.
- The transmitter will beep once.
- The LCD panel will show a siren if the chirps are enabled or "off" if the chirps are disabled.

**PSV** Passive function allows the passive arming mode to be enabled or disabled with the transmitter.

Note: This feature may not be available on all systems.

To enable or disable the passive arming mode:

- Press and hold Button 5 until the display shows PSV.
- The transmitter will beep five times.  
Release Button 5.
- The transmitter will beep once and the system will begin the passive arm mode
- The LCD panel will display "off" and vibrate twice if disabled.

**SND** Sound function allows disabling of the transmitter's confirmation tones. To turn the transmitter confirmation tones on or off:

- Press and hold Button 5 until the display shows SND.
- The transmitter will beep four times.



Release Button 5.

- The transmitter will beep once.
- The LCD panel will beep five times if enabled or vibrate and display "off" if the confirmation tones are disabled.

**VLT** Valet mode function sets and resets the security system valet mode.

\* this function is enabled only when the security system is disarmed











Set or reset the Valet mode:

Press and hold Button 6 until the display shows VLT.

- The transmitter will beep six times.

Release Button 5.

- The LCD panel will play a tone if the Valet mode was set "V" will be displayed indicating that the system is in Valet mode.
- The transmitter will beep twice if the Valet mode was reset. "V" will turn off indicating that the security system is out of Valet mode.

			
<b>System Armed</b> Indicates the alarm is On	<b>System Disarmed</b> Indicates the alarm is Off	<b>Warn Away</b> Indicates the warn-away has been triggered	<b>Trunk Release</b> Indicates the trunk or auxiliary function has been triggered
			
<b>Door Open</b> Indicates the door zone has been triggered.	<b>Shock Sensor</b> Indicates the shock sensor zone has been triggered.	<b>Battery Low</b> Indicates the transmitter battery need replacement	<b>Trunk Open</b> Indicates the trunk or hoodzone has been triggered.
			
<b>Alarm Clock</b> Indicates the programmable timer has been set	<b>Valet Mode</b> Indicates the system has been placed in Valet	<b>Panic</b> Indicates the panic mode has been	

## Remote Transmitters

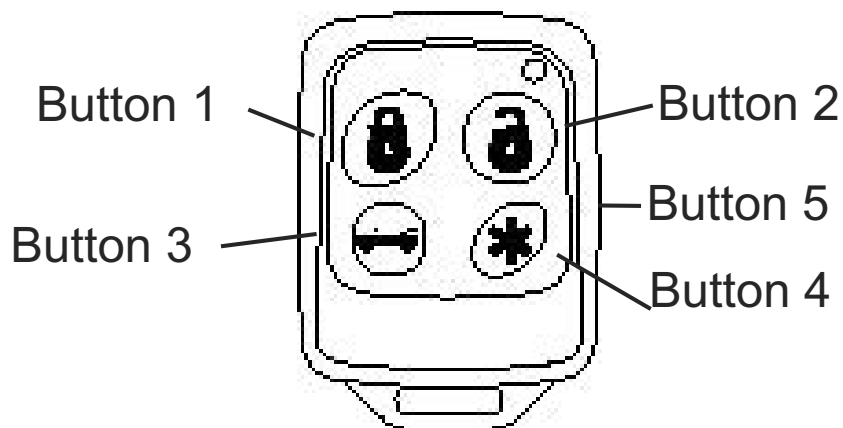

### Remote Transmitter Description

The Astra 777 Mobile is supplied with one 5-button Remote Transmitter used to control system operations.

**Button 1** Arms and Locks\* the system and when held for 5 seconds, activates the system's Panic feature. Button 1 also locks the doors when the system is in Valet Mode.

**Button 2** Disarms and Unlocks\* the system. Pressing Button 2 again operates the Passenger Unlock feature (if installed). Button 2 also unlocks the doors when the system is in Valet Mode.

**Button 3** Activates the Auxiliary 1 output. This output will remain on for as long as the button is pressed.

**Button 4** Activates the Auxiliary 2 output. This output will remain on for as long as the button is pressed.

**Button 5** is the Page Shift button. The Page Shift button will change the function of Buttons 1 through 4 each time it is pressed, allowing access to additional features or multiple car operation. Each time the Shift Button is pressed, the LED on the transmitter will illuminate and the transmitter functions will shift to the next page, allowing access to another set of features. Once shifted to another page (there are 4 pages total), the transmitter will remain on that page for 10 seconds or until a button is pressed, then return to page 1. Each time a transmitter button is pressed and held, the LED will flash a number of times to indicate from which page it is transmitting. Under normal operation, only pages 1 and 2 are used. Pages 3 and 4 are usually used for Two Car Operation (see page 3).

Shift then Button 1 Arms and Locks\* the system silently.

Shift then Button 2 Disarms and Unlocks\* the system silently.

\* **If the Optional Keyless Entry Feature is installed.**

## **Adding/Replacing One-Way Transmitters**

To replace lost or stolen transmitters or to add additional transmitters into the system, have all desired transmitters ready and follow the steps below.

**Note:** Up to 4 one-way transmitters can be programmed to operate the system. Any previously stored transmitter code will be erased if it is not programmed within the following sequence.

To program the transmitter(s):

1. Turn on the ignition key On, Off, On, Off, and back On.
  - The siren will chirp 3 times.
2. Press and hold the Override switch for 5 seconds.
  - The siren will chirp 5 times.
  - The LED will illuminate.
3. Press Button 1 on the first transmitter.
  - The siren will chirp once.
4. Press Button 1 on the first transmitter again.
  - The siren will chirp twice to indicate it has learned the code.
5. Repeat steps 3 and 4 for each transmitter (up to 4).
6. Turn off the ignition key.

## **Two Car Operation**

If two vehicles are equipped with Astra 777 Mobile systems, for convenience both can be operated using the same remote transmitter. If all four transmitters are to be used with both cars, program transmitters A and B into the first vehicle in the manner described above. Program transmitters C and D by pressing the Shift button twice before performing steps 3 and 4 above.

When finished programming the first vehicle, program transmitters C and D into the second vehicle as normal, then program transmitters A and B by pressing the Shift button twice before performing steps 3 and 4 above.

When programmed in this manner, the driver of the first car can also operate the second vehicle by pressing the Shift button twice and the desired function button.

## **Battery Replacement**

Your Remote Transmitter uses a 12 volt alkaline battery (type 23A), which will require replacement in time. Depending on the amount of use, the battery may last up to six months or more before it needs replacement.

When the battery needs replacing, the system's operating range will decrease or the transmitter LED may not be as bright.

In order to change the battery, first remove 2 screws from the back of the transmitter and separate the top and bottom halves of the case.

While replacing the battery make sure that the positive and negative terminals are positioned correctly, then carefully reassemble the transmitter case.

# System Operation

## Remote Arming

The system monitors 4 independent areas (**zones**) while armed: doors, hood/trunk, shock sensor and optional sensor input.

To Arm the System:

1 Turn off the ignition.

2 Press Button 1.

- The siren will chirp once.\*
- The doors will lock.
- The parking lights will flash once.
- The LED will turn on, to indicate the starter defeat is activated.

3 5 seconds after Arming:

- The LED will start blinking to indicate that the doors and hood/trunk inputs are being monitored.

**\* During Arming, if the system detects a bad sensor or an open zone, the system will chirp 4 additional times and ignore that input, but keep all other areas protected.**

Once Armed, the alarm will trigger when any of the following occurs:

- The doors are opened.
- The hood or trunk is opened.
- The shock sensor detects an impact to the vehicle.
- The optional sensor is disturbed.

When the alarm triggers, the siren will sound, the horn will honk, and the parking lights will flash. If the system is triggered by the doors, or hood/trunk, the system will alarm for 45seconds. If triggered by the shock sensor or optional sensor input, the system will alarm for 30 seconds.

In the event the alarm is triggered and remains triggered continuously by the same sensor or input during a single arming cycle, that sensor or input will be automatically bypassed until the next time the system is armed.

If the Shock Sensor detects a light impact to the vehicle, or the Optional Sensor's warn-away zone is disturbed, the siren will chirp 5 times as a warning indication.

## Remote Disarming

To Disarm the System:

Press Button 2

- The siren will chirp twice.\*
- The doors will unlock.
- The parking lights will flash twice and remain on for 30sec..
- The dome light will turn on.\*\*
- The LED will turn off.

**\* During Disarming, if the system was triggered while away from the vehicle, the siren will chirp 3 times, the parking lights will flash 3 times, and the LED will flash to indicate triggered zone. See Tamper Alert for zone listing.**

**\*\* If the optional Dome Light Activation Feature is installed.**

## **Tamper Alert**

If the system was triggered while away, the LED will flash to indicate which zone triggered the system after disarming and turning on the ignition. The LED indication will repeat 8 times.

LED Flashes:

flash = optional sensor

flashes = shock sensor

flashes = not used

flashes = door 5 flashes = trunk

10 flashes = main power interrupt or system was reset

example: flash-flash-pause-flash-flash-pause = shock sensor

## **Silent Arming/Disarming**

The system can be programmed to operate without Arm and Disarm chirp indications. When programmed for full-time silent operation, the siren will sound only when the system is triggered. The system is also capable of temporary silent operation if desired. Pressing the Shift button before Arming or Disarming the system will bypass the chirp confirmations and allow one-time silent operation.

**Note: The open zone warning chirps will not be bypassed when the system is Armed or Disarmed silently.**

## **Passive Arming**

When programmed for the optional Passive Arming feature, the system arms itself automatically, each time the ignition is turned off and all of the doors, hood, and trunk are closed.

To start the Passive Arming Process:

1. Turn off the ignition.
2. Open the door and exit the vehicle. Once all doors are closed and the dome light is off, the LED will begin flashing rapidly. Parking Lights will flash twice three seconds after passive arming cycle began.
3. After 30 seconds,  
The siren will chirp.  
The parking lights will flash.  
The doors will lock.\*  
The status LED will begin flashing.
4. The system is now armed.

**\* If the Passive Locking feature is selected.**

## **Panic Mode**

In the event of an emergency, the transmitter's remote Panic feature can be used to instantly trigger the alarm.

To activate the Panic Mode:

1. Press and hold Button 1 for 5 seconds.
  - The alarm will sound.
  - The parking lights will flash.
  - The doors will unlock\* allowing access to the vehicle.
2. Press Button 2 to stop Panic Mode.

**\* If the ignition is on when the Panic feature is activated, the doors will lock for personal safety.**

## **Emergency Override**

If the transmitter becomes lost or inoperable, the system can still be disarmed using the following procedure. Before beginning this procedure be sure to have the ignition key ready and know the location of the override switch.

To Emergency Override the system:

1. Unlock the door using the key.
2. Enter the vehicle.
  - The system will trigger and the siren will sound.
3. Turn the ignition key on.
4. Press and hold the override switch until the system disarms.
5. The vehicle will now be able to start.

## **Optional Coded Emergency Override**

As an extra measure of security, the system is equipped with an optional Coded Emergency Override feature. Once an Emergency Override Code is chosen and programmed during installation, the system can no longer be disarmed using the standard override procedure.

To Emergency Override the system using the Code:

1. Follow steps 1-3 above.
2. Press the override switch a number of times equal to the Disarm code, and continue holding for 10 seconds on the last press.
  - The system will disarm. If the code is entered incorrectly, turn off the ignition and begin again.

To set the Emergency Override Code:

1. Turn on ignition.
2. Within 5 seconds, press the valet switch 5 times.

The siren will provide one long chirp, indicating that you have entered Programming.
3. Press the valet switch 4 times.

The siren will chirp each time the valet switch is pressed.
4. Within 5 seconds, press Button 3 on the transmitter.

The siren will chirp 3 times
5. Press the valet switch the number of time equal to the desired code (from 1-15).

6. Turn off the ignition then arm the system.

7. Disarm the system using the new Override Code to permanently store the new code.

Note: If the code set procedure is not properly performed, turn off the ignition and begin again. The override code will not be permanently stored until the code is used to disarm the system.

### **Automatic Rearming**

The Automatic Rearming feature is designed to protect the vehicle in the event the system is accidentally disarmed. With the Automatic Rearming feature enabled, the alarm will automatically rearm and lock 30 seconds after disarming.

\* **Note** Door open trigger does not stop the Rearm Cycle

### **Valet Mode**

The Valet Mode temporarily disables the security system so the vehicle may be operated by a mechanic or parking attendant.

To activate or deactivate the Valet Mode:

1. Turn on the ignition.

2. Press and hold the override switch for 5 seconds.

- The siren will chirp once and the LED light will stay ON to confirm the Valet Mode is on.

- The siren will chirp twice and the LED light will turn OFF to confirm the Valet Mode is off.

3. Turn off the ignition.

seconds, then release. · The LCD transmitter will beep continually and the "DRIVER CALLING" icon will appear · Press and release button 5 to turn off transmitter page.

While in Valet Mode the remote transmitters will continue to lock and unlock the doors, and operate the optional auxiliary functions.

### **DRIVER CALLING/PAGE FEATURE**

The Astra 777 Mobile is equipped with a Driver Calling or Paging feature that allows the system to send a page to the LCD transmitter in the event the transmitter has been misplaced or lost (within 1500 feet)

To activate the Driver Calling/Page feature:

1. Locate the Valet/Emergency Override button in your vehicle (Ask your installation shop)

- With the ignition switch OFF, press and hold the Valet/Emergency override button for 2 seconds, then release.

### **Ignition Controlled Door Locks**

For added safety, the Ignition Door Locking feature allows vehicles equipped with power door lock systems to automatically lock the doors when the ignition is turned on, and unlock the doors after the ignition key is turned off. If a door is open when the ignition is turned on, the ignition locking feature is disabled to protect against locking the keys inside the vehicle.

### **Dome Light Activation**

If the optional Dome Light Activation feature is installed, the dome light will turn on when the system is disarmed using the Remote Transmitter. The dome light will remain on for 30 seconds or until the ignition is turned on.



## Extended Features

### **Auxiliary Function Outputs**

The Astra 777 Mobile system is equipped with 2 Auxiliary Outputs allowing the convenience features of the system to be further expanded. These outputs can be used to add a number of optional features such as: power trunk release, remote engine start, power window activation, power sunroof control, and more.

### **Disarm with Auxiliary Function**

If Auxiliary 1 is installed to activate the vehicle's trunk release, the system can be programmed to automatically disarm the alarm when the trunk is opened using the transmitter. In this manner, the trunk can be accessed without first disarming the alarm.

### **Remote Sensor Disable**

When parking the vehicle in areas susceptible to unwanted disturbance from animals or strong weather conditions that could cause the sensors to trigger, the sensor inputs can be temporarily bypassed using the Remote Transmitter, preventing possible false alarms.

To disable the sensor inputs :

1. Arm the system normally.
2. Within 5 seconds of Arming the system, press the Arm button again.
  - The siren will chirp 5 times and the parking lights will flash 5 times to indicate the sensors are disabled.
  - The sensors will remain disabled until the next arming cycle.

### **Anti-Carjacking Protection**

For a higher level of personal security, the system is equipped with three programmable Anti-Carjacking modes. When any Anti-Carjacking mode is triggered, the parking lights will flash twice to confirm activation. After 90 seconds the siren will begin chirping for 15 seconds as a warning, prior to entering full alarm mode. During the full alarm mode, the siren will sound, the parking lights will flash, and the horn will honk for up to five minutes or until the system is reset.

**Manual.** When selected, pressing Button 4 of one way remote, or page 2 button 3 of the LCD remote, with the ignition ON will automatically trigger the Anti-Carjacking feature. Press the Button again to reset the Manual Anti-Carjacking mode.

**Passive.** When selected, the Anti-Carjacking feature will activate whenever a door is opened while the ignition is on. Press the Valet switch 1 time to reset the Passive Anti-Carjacking mode.

**Full-Time.** When selected, the Anti-Carjacking feature will automatically activate each time the ignition is turned on. Press the Valet switch 1 time while the ignition is on to reset the Passive Anti-Carjacking mode.

Note: The desired Anti-carjacking mode must be programmed during installation.

## System Installation

1. Thoroughly read and become familiar with the installation instructions before beginning the installation.
2. Review system contents:
  - Main Unit 2 One-Way 5-Button Remote Transmitter
  - Siren Shock Sensor Harnesses Receiver Antenna
  - 14-Pin main harness
  - 4-Pin shock sensor harness
  - 3-Pin door lock harness
  - LED harness
  - Valet Switch harness
  - Receiver Harness
3. Verify with the owner, the mounting locations for all visible components, including the LED and Override switch.
4. Verify with the owner, the optional features of the Astra 777 Mobile and the functions that must be programmed during installation.
5. Inspect and perform a function test of all vehicle systems before and after the installation.
6. Always use a Volt / Ohm meter for testing vehicle circuits. Never use a test light.
7. Always look before drilling any holes or mounting self-tapping screws. Be sure fuel lines and exterior wiring looms are clear as they are often close to the chassis and difficult to see.
8. Protect all wires running from the engine compartment to the interior of the vehicle by covering with electrical tape and split loom tubing. Be sure to use a grommet when routing wires through the firewall.
9. Properly fuse any additional accessories such as window modules, door lock actuators, etc., making sure to power them separate from the alarm module. This will ensure the functionality of the security system in the event of an accessory failure.

### **Mounting the Control Unit**

The control unit must only be mounted in the interior of the vehicle. Do not mount the main unit in the engine compartment. Choose a mounting location that will not be easily accessible to a thief, and will not interfere with the operation of any vehicle components such as foot pedals, steering column, air vents, seat rails, etc.

Do not mount the control unit until after setting the internal jumpers and performing a complete operation check of the system. After installation is complete and performance verified, the control unit can be easily mounted using wire ties through the mounting tabs on the bottom of the unit.

### **Mounting the Siren**

Choose a siren mounting location that is away from heat sources such as exhaust manifolds, and where it cannot be easily accessed from underneath the vehicle. Be sure to face the siren downward to prevent the collection of water in the siren's housing.

Always route all wires from the engine compartment into the interior of the vehicle through a proper grommet.

### **Mounting the Shock Sensor**

Choose a suitable interior mounting location for the shock sensor that provides ample coverage of the vehicle. Keep the sensor away from the vehicle's ECM or other sources of electrical interference. Suggested mounting locations include air conditioning ducts, dashboard braces, or center console supports.

During proper operation, the shock sensor will detect impacts to the vehicle only and will not usually be triggered by slow rocking movements of the vehicle like those caused by wind.

## System Wiring

### 14-Pin Main Harness

Pin 1 **RED WIRE**: +12V Battery Input (15A Fuse). The RED wire must be connected to a clean source of continuous +12V power.

Pin 2 **WHITE WIRE**: Parking Light Output (+/-) relay. Connect the White wire to the circuit that shows +12V or ground only when the parking lights are on and set the internal parking light relay jumper to the proper polarity. For parking light circuits exceeding 10 amps, a relay is required. For vehicle's with independent left and right parking light circuits, diodes must be installed to keep the circuits separate. NOTE: Do not connect the WHITE wire to the vehicle's headlight circuit.

Pin 3 **BROWN WIRE**: Siren Output (+) 3A. The BROWN wire must connect to the siren's red wire. The BLACK siren wire must be grounded.

Pin 4 **BLUE/WHITE**: Passenger Unlock output (-) 500mA. Connect to an optional relay to unlock the passenger doors for two-stage unlock (see Two Stage Door Lock Diagrams).

Pin 5 **WHITE/RED WIRE**: Auxiliary 2 Output (-) 500mA. Connect to a relay or module for an optional feature such as power window activation or remote start, etc.

Pin 6 **ORANGE WIRE**: Armed Output (-) 500mA. The ORANGE wire provides a ground output while armed to activate an optional starter defeat relay or other device such as a power window control module.

Pin 7 **BROWN/WHITE WIRE**: Horn Output (-) 500mA. Connect to an optional relay to activate the vehicle's horn when the alarm is triggered.

Pin 8 **BLACK/WHITE WIRE**: Dome Light Output (-) 500mA. Connect to an optional relay for dome light activation.(See GREEN and VIOLET door trigger wires).**NOTE: MUST USE**

Pin 9 **BLUE WIRE**: Trunk/Hood trigger Input (-). Connect the BLUE wire to the trunk and/or optional hood pin switches. The switch must provide a ground output when opened.

Pin 10 **GRAY WIRE**: Auxiliary 1 Output (-) 500mA. Connect to a relay or module for an optional feature such as trunk release, etc.

Pin 11 **YELLOW WIRE**: +12V Ignition Input. The YELLOW wire must connect to a main ignition wire at the ignition harness. This wire must show +12V when the ignition is on.

Pin 12 **BLACK WIRE**: Ground Input (-). The BLACK wire must connect to a solid chassis ground. Clean away any paint or dirt to insure the best possible ground.

Pin 13 **VIOLET WIRE**: Positive door trigger Input (+). Connect to the door switch circuit wire that shows +12V when the door is open. This type of door circuit is usually found on Ford vehicles.

Pin 14 **GREEN WIRE**: Negative door trigger Input (-). Connect to the door switch circuit wire that shows ground when the door is open.

**Plug-in Connectors 3-Pin White Door Lock Connector:** Plug-in connector port for door lock harness or optional door lock relay module. · BLUE WIRE - negative unlock output (-) 500mA. · GREEN WIRE - negative lock output (-) 500mA.

**2-Pin Red Connector:** Plug-in connector port for LED. Mount the LED in an area where it may be easily seen from either side of the vehicle.

**2-Pin Blue Connector:** Plug-in connector port for valet switch. Mount the valet switch in an area that is easily accessible from the driver's position.

**4-Pin White Connector :** Plug-in connector port for dual stage shock sensor.

## Humper Settings

### Jumper Selection

Carefully separate the top and bottom halves of the main unit case. Once the cover is removed, the parking light polarity jumper will be visible next to the parking light relay. Set the jumper for the correct polarity output as described below, then reassemble the main unit case.

**Parking Light Output.** Selects the polarity (+/-) for the output of the on-board Parking Light relay. Left Pin + Center Pin = positive Right Pin + Center Pin = negative

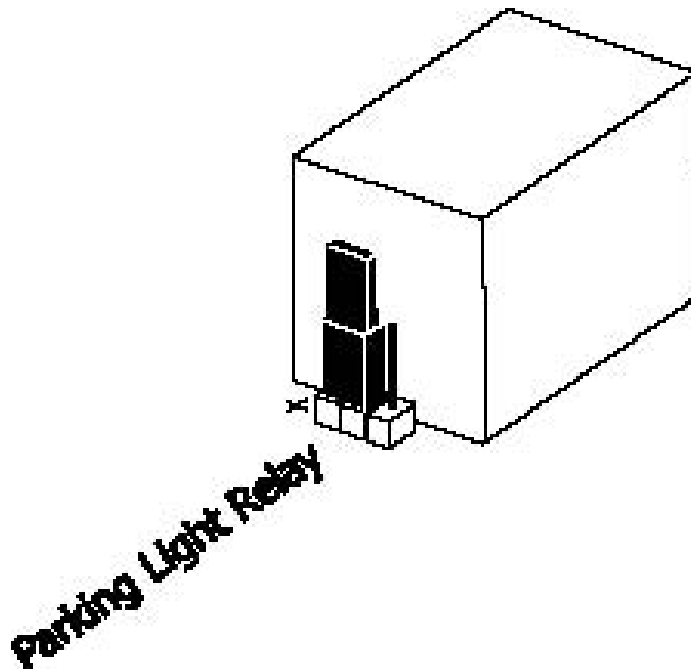

default setting shown

# System Programming

## Entering System Programming

To enter System Programming:

1. Turn on ignition.
2. Within 5 seconds, press the valet switch 5 times.
  - The siren will provide three chirps, indicating that you have entered Programming.
  - LED Blinks if GPS location is established, LED is ON if not.
3. Press the valet switch the number times equal to the System Option you want to change.
  - The siren will chirp each time the valet switch is pressed.
4. Within 5 seconds, press the transmitter button corresponding to the desired operating mode for that System Option.
  - The siren will chirp to indicate the setting.
    - 1 chirp = Button 1
    - 2 chirps = Button 2
    - 3 chirps = Button 3
5. When you are finished, turn off the ignition to save the changes.

## Default Reset

Following this procedure will set all Programmable System Options to factory default settings.

1. Enter System Programming.
2. Press Transmitter Button 3.
  - The siren will chirp 6 times indicating that the reset signal was received.
  - All Programmable System Options are now set to factory default settings.
  - The Valet Mode is off.
3. Turn off ignition.

## Programmable System Options

The following is a description of the programming options. Some program branches control more than one option, and may require accessing a particular branch number twice in order to program all desired features.

1. **Horn Chirps with Arm & Disarm.** Selects one of two modes: Normal, Horn Chirps Normal. When selected, the horn will honk only when the alarm is triggered. Horn Chirps. When selected, the horn will provide the arm/disarmed trigger indications, allowing the siren
2. **Arm Mode.** Selects one of two modes: Manual Arming or Passive Arming.
3. **Passive Door Locking.** Selects whether or not the system will automatically lock the doors during Passive Arming.
4. **Ignition Controlled Locks/ Override Code Set.** This dual program branch sets Ignition Controlled Locking and programs the optional Emergency Override Code. If Lock Only is selected, the doors will not automatically unlock when the ignition is turned off.
5. **Ignition Door Unlocking.** Selects whether or not the system automatically unlocks the doors when the ignition is turned off. The Ignition Door Locking feature may be programmed to unlock all doors or the driver's door only. If driver's door only is selected, the optional Passenger Unlock fea-



ture must be connected. (See Two Stage Door Lock Diagrams)

6. **Ignore Open Door Report.** Bypasses the open zone warning chirps for vehicles equipped with a residual dome light circuit that remains ON for a period of time after closing the door.

7. **Auto Rearming Mode.** When selected, the system will automatically re-arm and lock 30 seconds after it has been disarmed regardless if a door is open or closed.

8. **Door Unlock Pulse.** Selects between one pulse or two pulse operation for the door unlock output. Vehicles that require two pulses on the proper wire to unlock the doors can be interfaced directly without the use of relays or any additional circuitry by programming the system for double unlock pulse.

9. **Arming Chirps.** Selects between normal and silent operation.

10. **Disarm with Auxiliary 1.** When selected, activating the Auxiliary 1 output (usually used to open the trunk) will disarm the alarm.

11. **Door Lock Pulse Length.** Selects between a 1, 3 or 0.1 second output for door locking and unlocking. Program to 3 seconds for vehicles equipped with vacuum door locking systems.

12. **Anti-Carjack Type.** Selects one of three modes for Anti-Carjacking: Active, Passive, or Full-Time. Manual. When selected, pressing Button 4 will automatically engage the Anti-Carjacking feature. Passive. When selected, the Anti-Carjacking feature will activate whenever a door is opened while the

13. **Anti-Carjack Mode.** Enables Anti-Carjacking protection.

ignition is on. Full-Time. When selected, the Anti-Carjacking feature will automatically activate each time the ignition is turned on.

14. **Horn Honk Output.** Selects the output, when activated, to be pulsing or constant.

15. **Aux 2 Auto Activate with Arm.** When selected, the Auxiliary 2 output will activate when the system is armed. This feature can be used to roll-up windows, close sunroofs, activate accessories, etc.

16. **Auxiliary 1 Mode.** Selects from momentary, 10 second timed, or latched operation for Auxiliary 1.

Momentary operation provides an output for as long as the transmitter button is pressed. Timed operation provides an output that turns on for 10 seconds each time the transmitter button is pressed. If the button is pressed again during the 30 seconds, the output will turn off.

Latched operation provides an output that turns on when the transmitter button is pressed and remains on until the transmitter button is pressed again.

17. **Auxiliary 2 Mode.** Selects from momentary, 10 second timed, or latched operation for Auxiliary 2.

Momentary operation provides an output for as long as the transmitter button is pressed.

Timed operation provides an output that turns on for 10 seconds each time the transmitter button is pressed. If the button is pressed again during the 30 seconds, the output will turn off.

Latched operation provides an output that turns on when the transmitter button is pressed and remains on until the transmitter button is pressed again.

18. **Ignition Armed Mode.** When enabled, the security system may also be manually armed and disarmed using the transmitter, while the ignition is on.

19. **Extended Parking Lights.** When selected, the parking lights will remain ON for 30 seconds

	<b>Brunch Feature</b>	<b>Button 1 (default)</b>	<b>Button 2</b>	<b>Button 3</b>	
1	Horn Chirps w/ Arm&Disarm	Normal	Horn Chirps		after disarming the system.
2	Arm Mode	Manual Arming	Passive Arming		
3	Passive Door Locking	Disabled	Enabled		
4	Ignition Controlled Locks	On	Off	Set Override Code	
5	Ignition Controlled Unlock	All	Driver Only	Disabled	
6	Ignore Open Door Report	Off	Ignore		
7	Auto Rearming	Disabled	Enabled		
8	Door Unlock Pulse	Single	Double		
9	Arming Chirps	Normal	Silent		
10	Disarm with Aux 1	Disabled	Enabled		
11	Door Lock Pulse Length	1 second	3 seconds	0.1 seconds	
12	Anti-Carjack Type	Manual	Passive	Full-time	
13	Anti-Carjack Mode	Disabled	Enabled		
14	Horn Honk Output	Flashing	Continuous		
15	Aux 2 Activate on Arm	Disabled	Enabled		
16	Aux 1 Mode	Pulsed	Timed	Latched	
17	Aux 2 Mode	Pulsed	Timed	Latched	
18	Ignition Armed Mode	Disabled	Enabled		
19	Extended Parking Lights	On	Off		
20	Warn-Away Pager Report	Enabled	Disabled		
21	Smart Siren Mode	Disabled	Enabled		
22	Cellular Networkk	Reset			

20. **Warn-Away Pager Report.** When Enabled, Warn-Away report will be sent to the pager. If Disabled no Warn-Away report will be sent to the pager.

21. **Smart Siren Mode.** When Enabled works with Optional ScyTek MP3 Player Siren Unit.

22. **Cellular Network Reset.** Re-establiish Network Communication .

# Door Lock Diagrams

Follow the diagrams below for connecting basic door lock systems. For Two Stage door lock systems (separately unlocks driver and passenger doors) see following pages.

## Negative Trigger

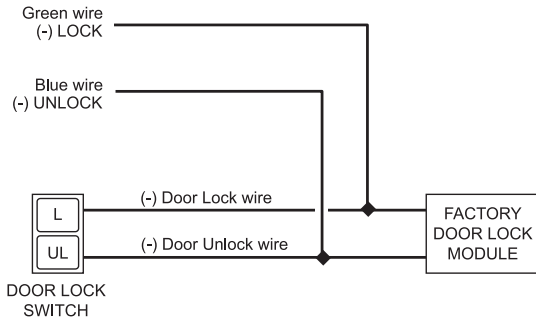

## Positive Trigger

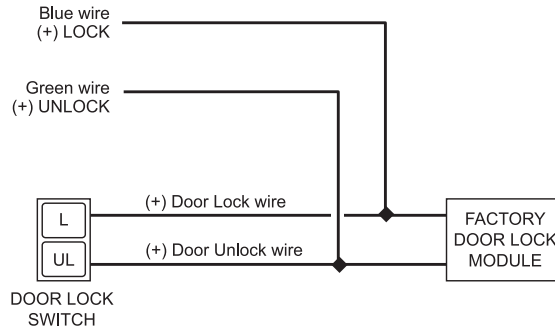

## Reverse Polarity

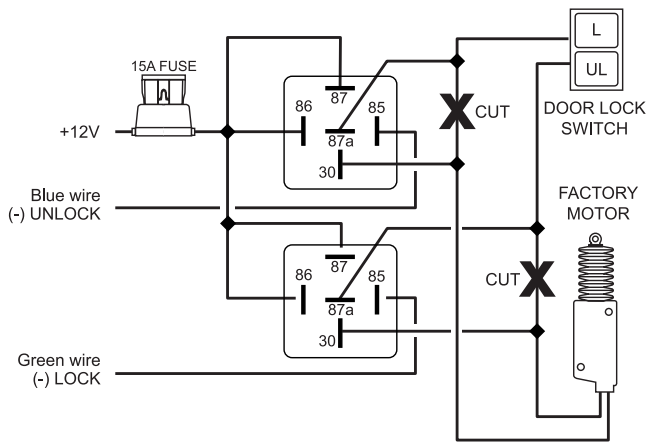

## Vacuum

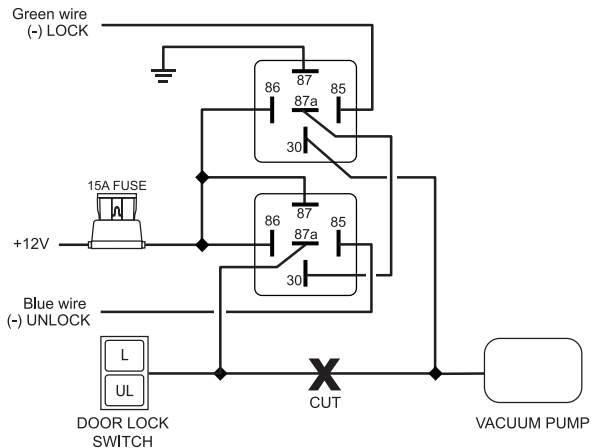

## Adding Actuators

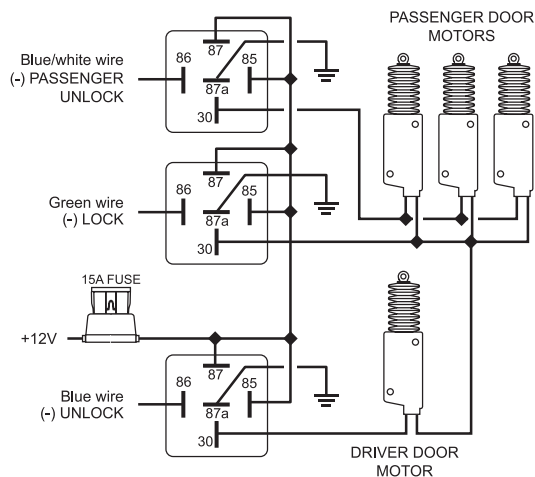

## Two Stage Door Lock Diagrams

The Astra 777 Mobile is equipped with a dedicated Passenger Unlock output allowing Two Stage Door Lock operation. When connected as shown below, disarming the system will unlock only the driver's door. Pressing the disarm button again will unlock all doors.

### Two Stage Negative Trigger

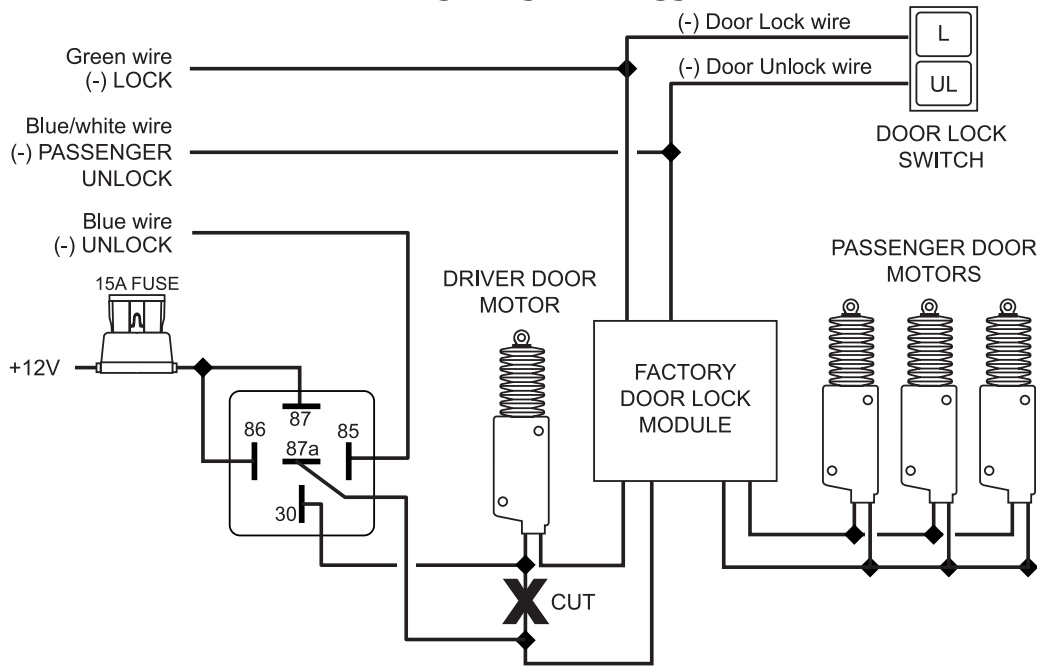

### Two Stage Positive Trigger

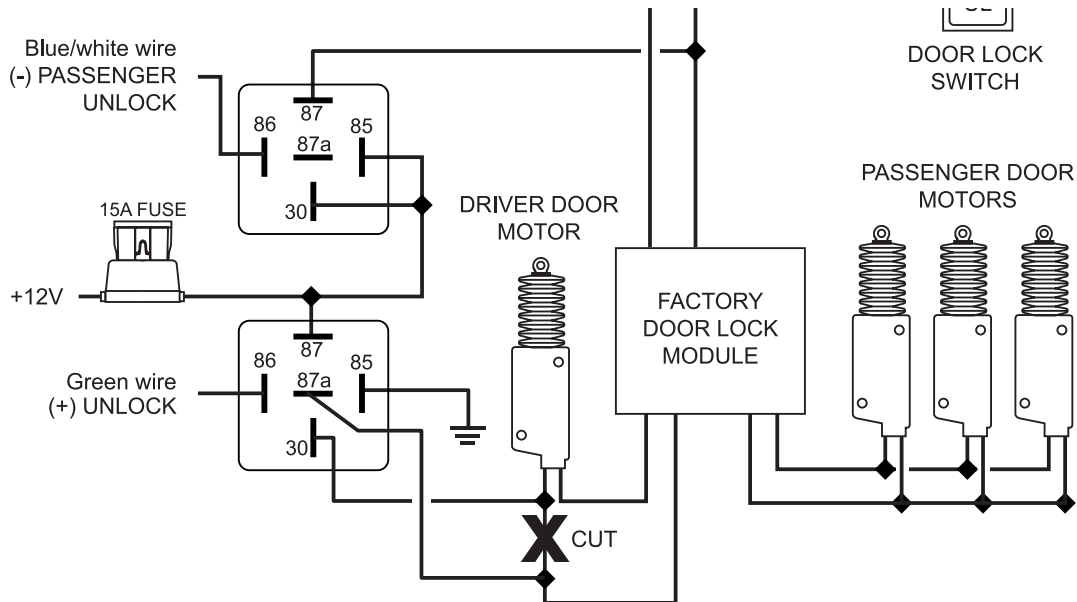

## Two Stage Reverse Polarity

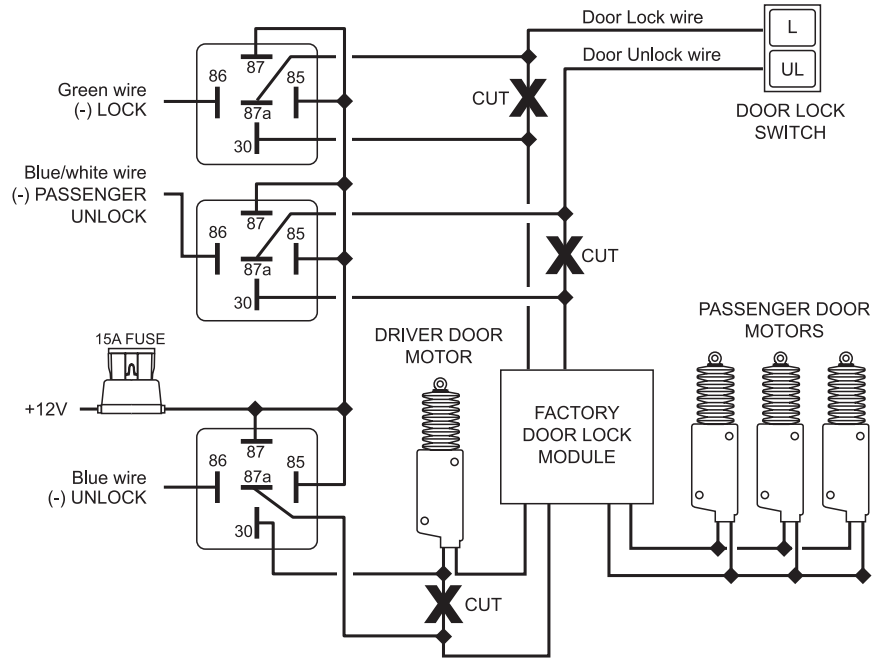

## Two Stage Adding Actuators

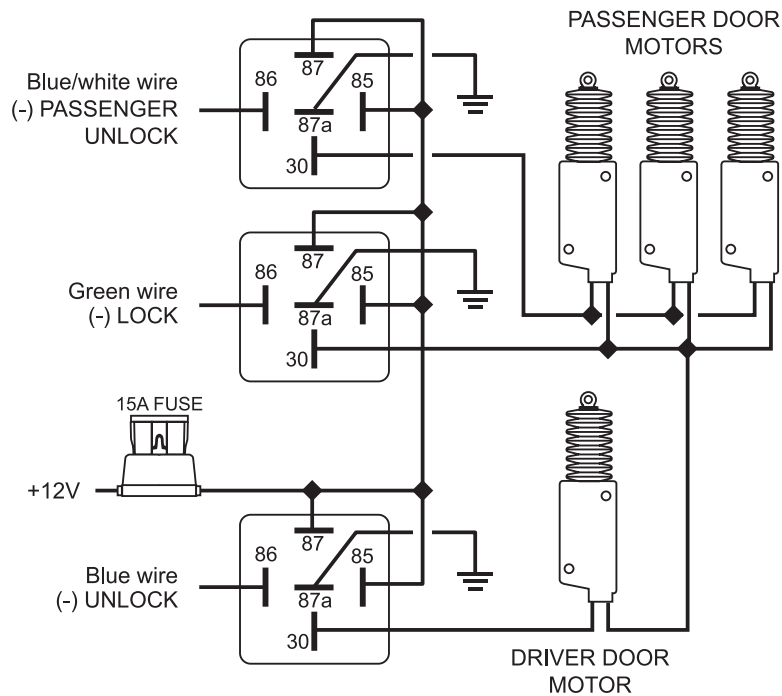

## Technical Information

### **FCC ID: OARRXAM2000**

This device complies with Part 15 of FCC Rules.

Operation is subject to the following two conditions:

- 1) This device may not cause harmful interference.
- 2) This device must accept any interference received, including interference that may cause undesired operation

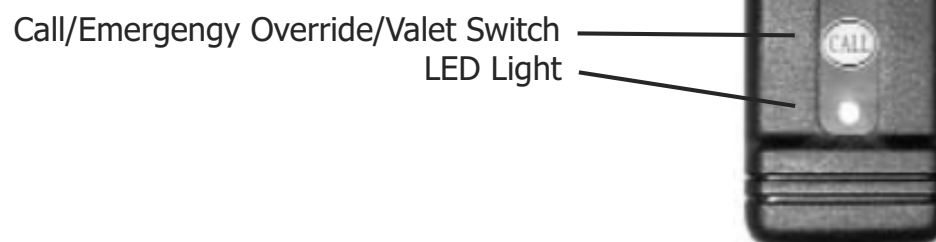





# Wiring Diagram

## Astra 777 Mobile

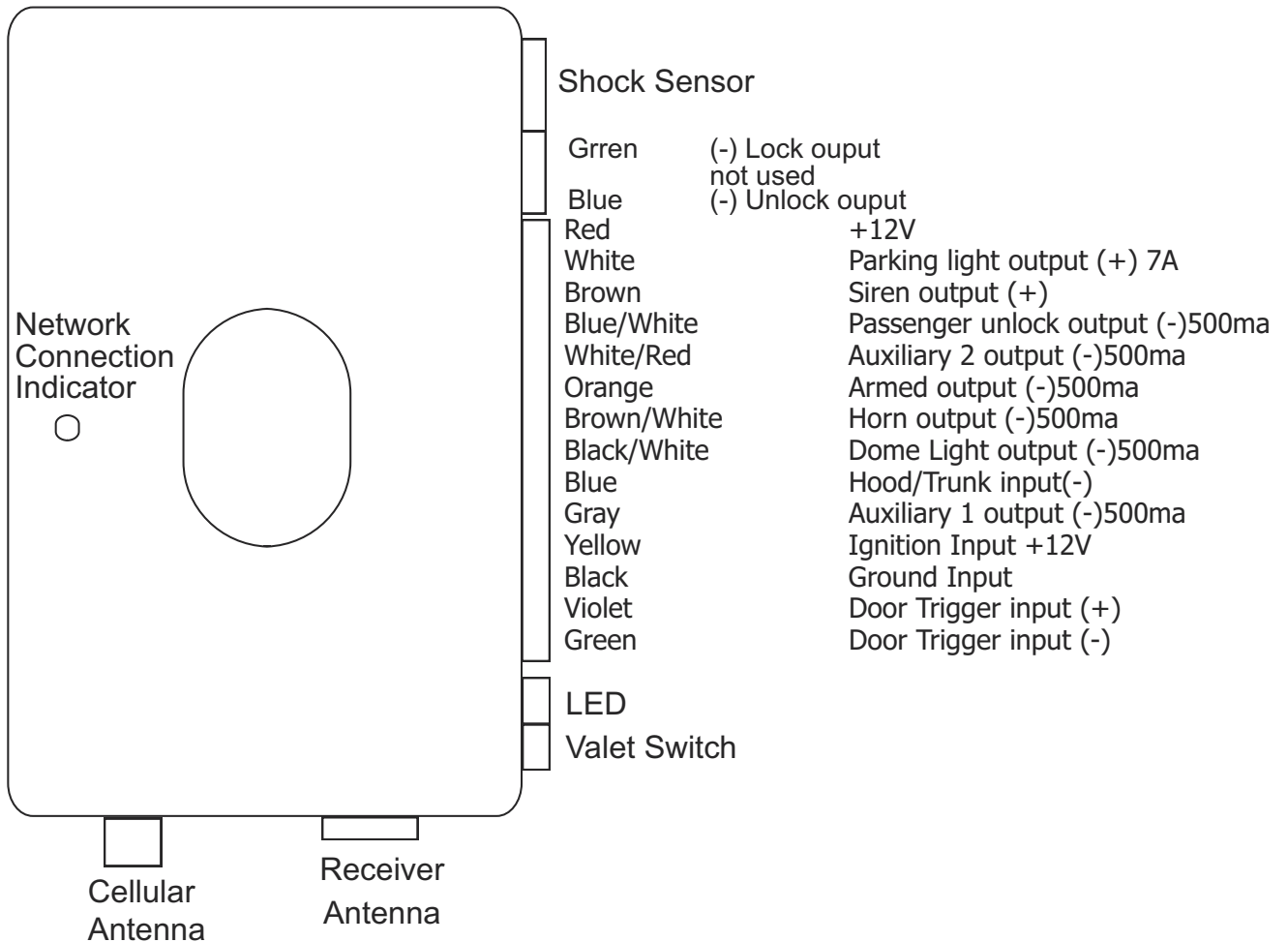

**ScyTek Electronics**  
**11627 Cantara Street**  
**North Hollywood, CA 91605**  
**www.scytek.net**